

**JIVM2020
Webinar**

RICOH
imagine. change.

Business Opportunities under COVID-19

- Printing Application Proposal by RICOH -

WFP Business Department
Wide Format Printing Business Center
Industrial Printing Business Group
RICOH Company, Ltd

Mahiro Takizawa



Ricoh aims to become a leading provider of industrial printing solutions that contribute to more eco-friendly production processes for safer and more reliable clothing, food, and housing



Ricoh's inkjet technology will contribute to solving social problems



Wide Format Printer will focus on 「Housing」

Market trend “With” COVID-19

Don't you often see signage like this recently?

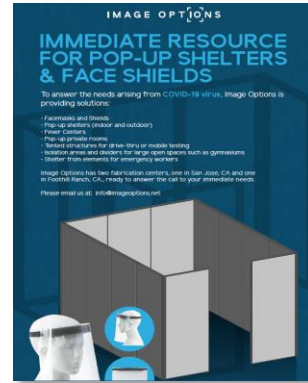

Cost

On Demand

Short Delivery Time





Market trend “With” COVID-19



Signboard

Suitable for UV Flatbed Printer



Direct Print



Quick delivery



On demand

Sticker / Flag / Poster

Suitable for Latex Roll to Roll Printer



Direct Print



Quick delivery



On demand

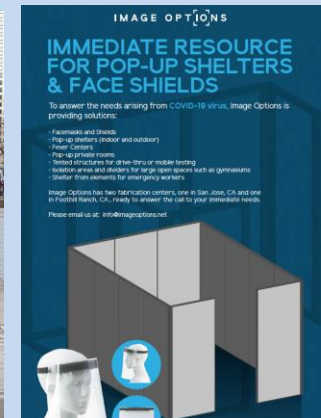



Case Study

Italian customer starts manufacturing protective masks for medical use with RICOH Pro T7210

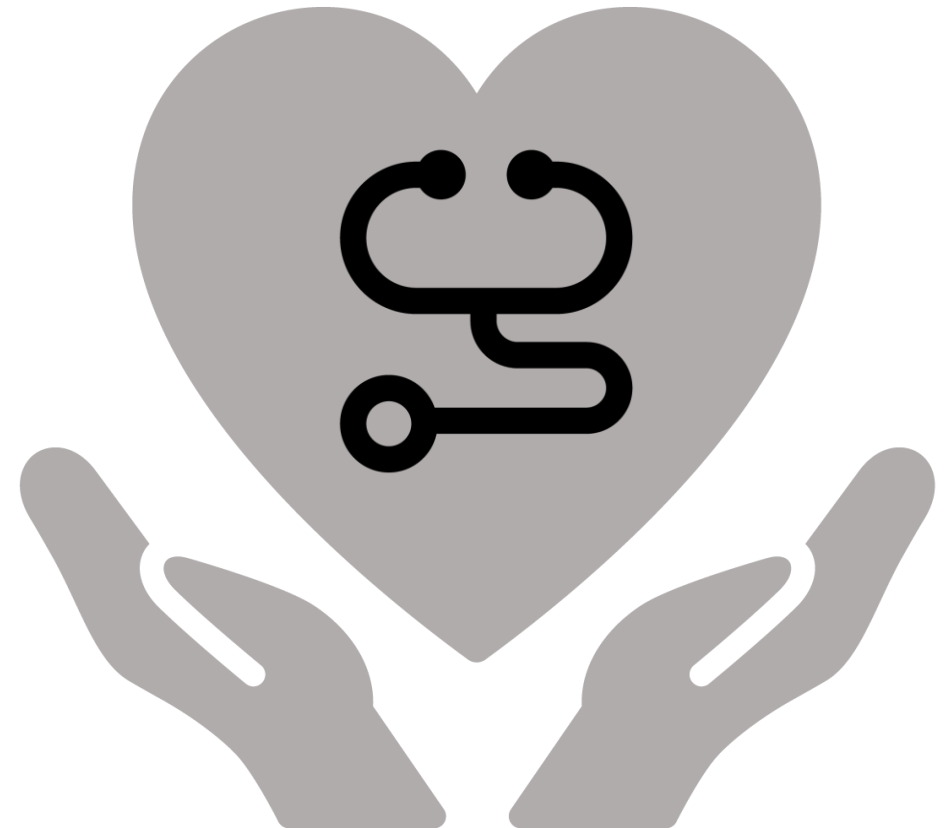



Market trend “With & After” COVID-19

Demand for interior decoration are increasing

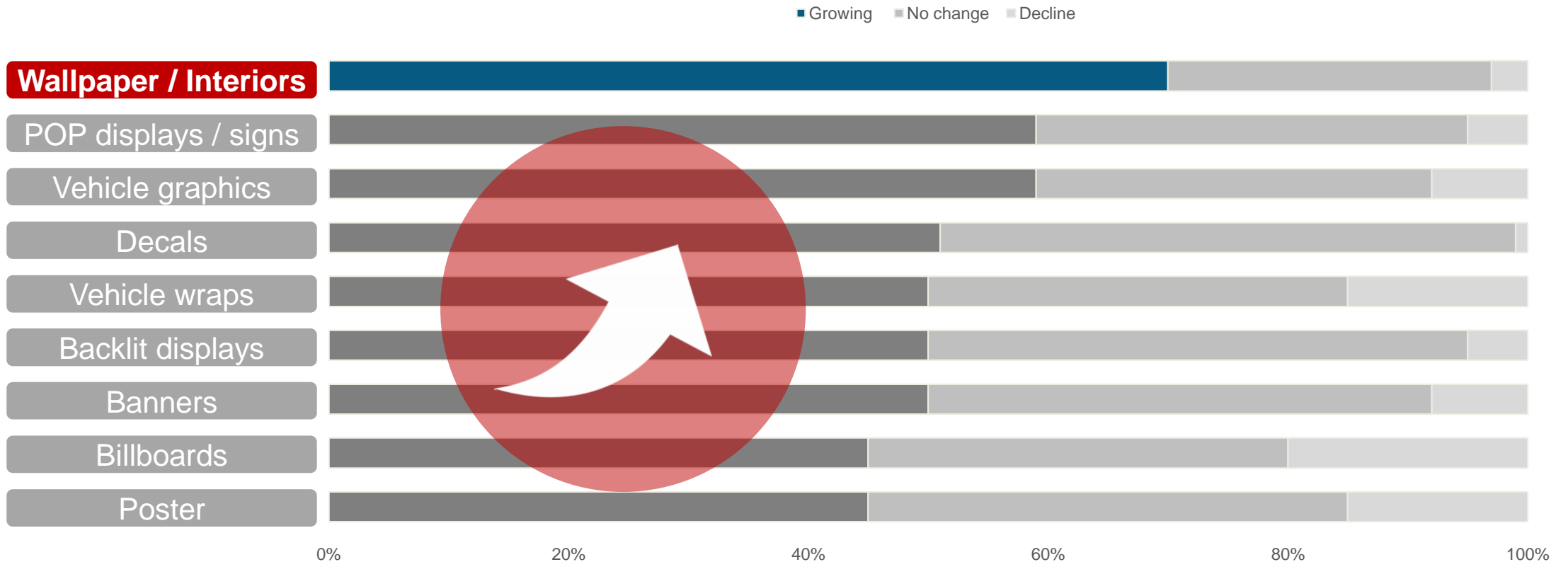

Source : 2019 Wide Format Application Opportunities, Info Trend / Keypoint 2019

Diversification of work styles

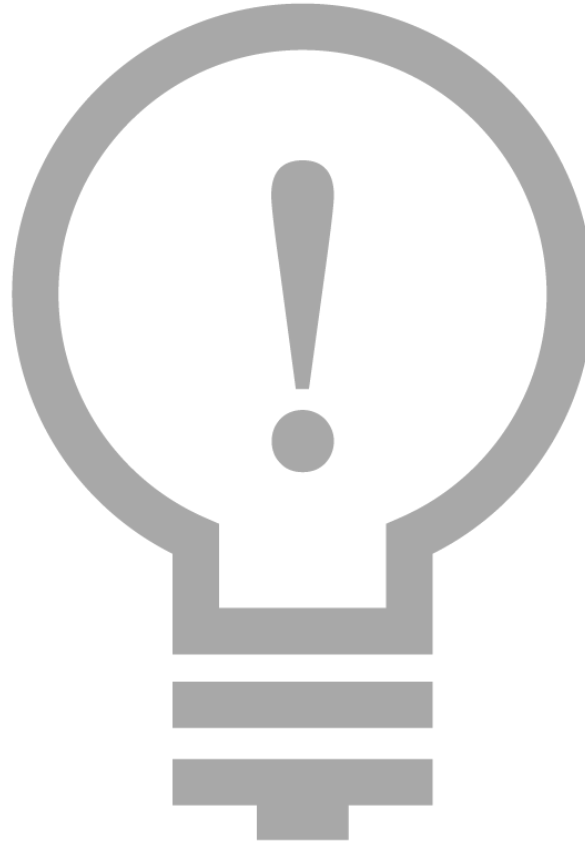

Spending more time at home

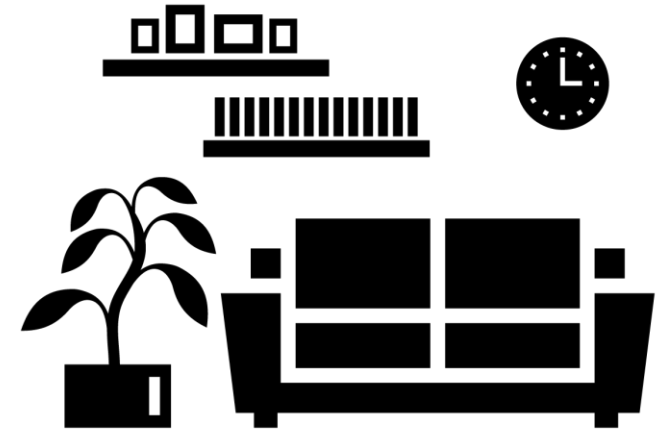

Applications that will increase interest in interior decoration

Market trend “With & After” COVID-19

Wall paper / Fabric board



Painting / Wall / Tabletop



Market trend “With & After” COVID-19

Easy 2 Step

Step 1. Print

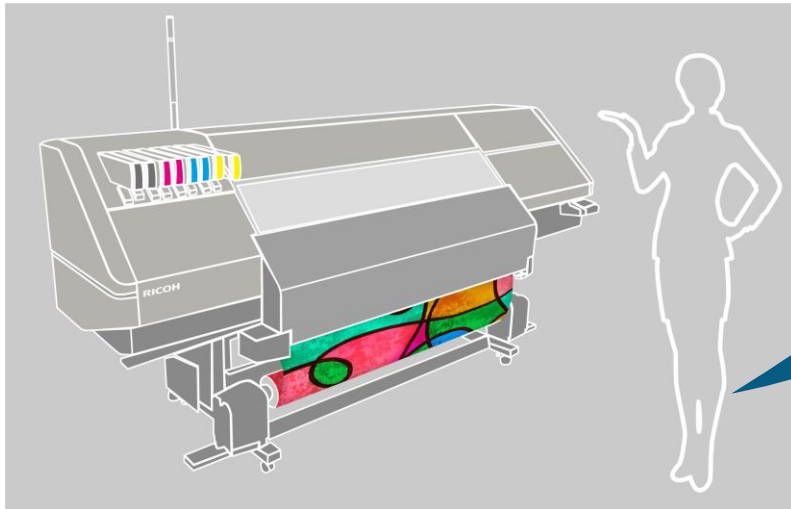

Step 2. Attach to a frame



Complete



Market trend “With & After” COVID-19

A simple room become stylish

BEFORE



AFTER



Color Consistency

Productivity



Safety



RICOH Pro Series

Roll to Roll Printer

RICOH Pro L5100 Series



Flatbed Printer

RICOH Pro T7210 / TF6250



High Productivity & High Cost Performance



Industry-leading High Productivity & High Cost Performance

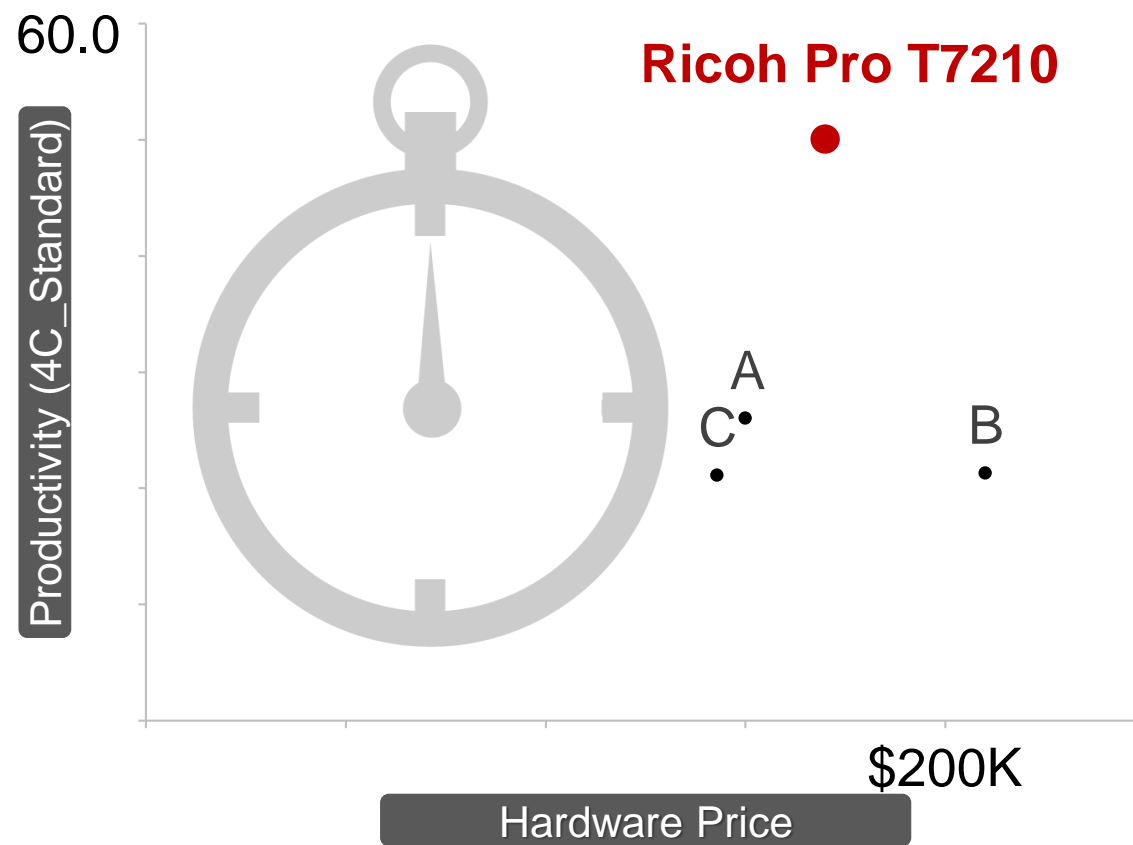
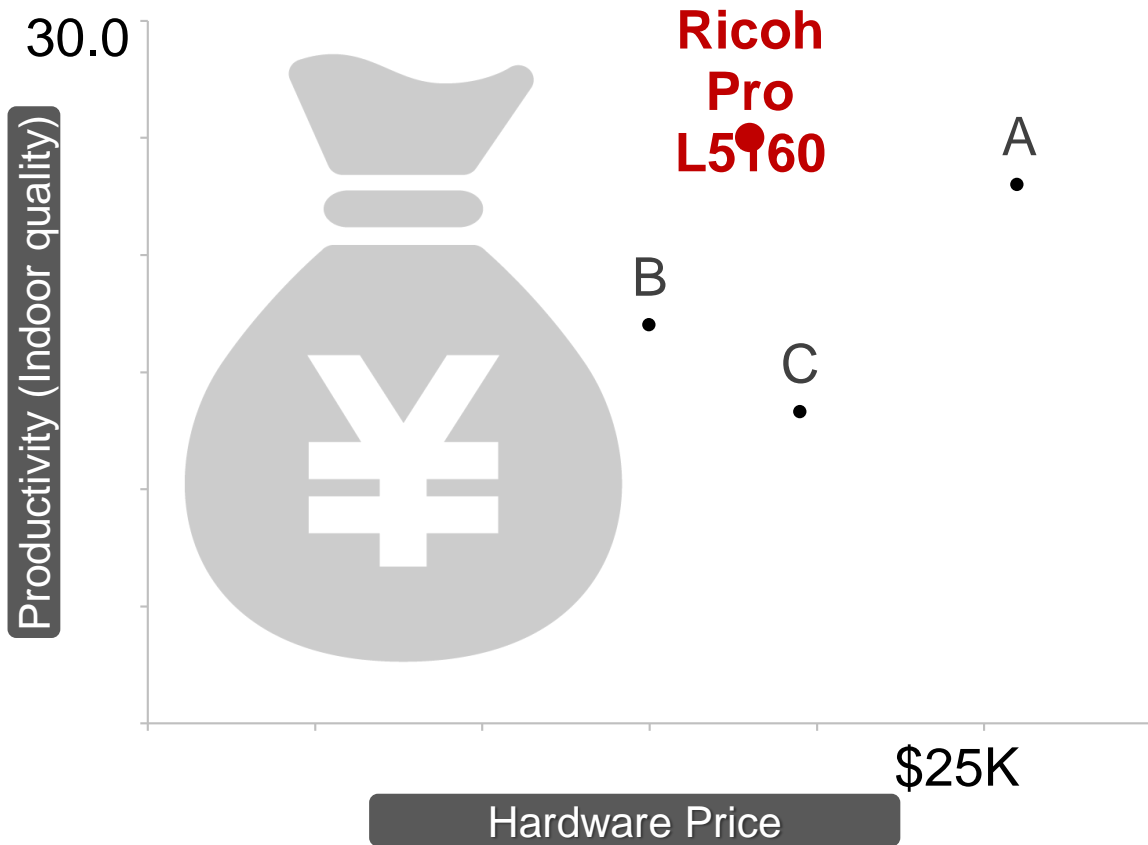



CONSISTENT COLOR

ACCURATE COLOR

COLOR COMPOSITION



A woman with brown hair is looking through the eyepiece of a microscope. The microscope's body is light grey. The text 'Max Resolution' is overlaid in a blue box, and '1200dpi x 1200dpi' is overlaid in white text below it.

Max Resolution

1200dpi x 1200dpi



RICOH Pro T7210



Case Study 2

By unifying the colors, the rooms have a sense of unity.
Reception room at RICOH Head Office





**Let's create an enjoyable lifestyle
with your ideas and
Ricoh's wide-format printers!**





Q&A





Reference

zjc_ricoh_industrial_printer@jp.ricoh.com

RICOH
imagine. change.